

Western Model A News

VOLUME 42, ISSUE 5

MAY 2021



Model A Restorers Club of Western Australia, Inc.



NOTE FROM THE PRESIDENT

Dean Roberts

president@modelafordclub.com.au

Well, I guess I can't make the excuse this month that "I didn't have time to get something to lan".

By the time you read this, hopefully we are out of our 3 day lock-down and things are back to normal. That is, a WA normal.



If so, the southwest run has started and on Monday 3rd, Jenni and I will be catching up with the group in Busselton. I must say, we are looking forward to the break and enjoying everyone's company.

Last weekend, I attended the "Shannon's Classic Car Show" as part of the organising group. I must say that it has given me a greater appreciation of the work that goes into running an event like that. Although it is put on by the CMC, a big thanks must go to Paul Markham who basically put the whole thing together. On behalf of the club, I have passed on our thanks for the effort he has put in over the last 5 years. This was his last year, and the CMC is looking for a volunteer to put next year's event together. If you think you would like the job, or know someone who would, please let me know and I will pass on your details.

We did have a CMC meeting last Monday, and I got the chance to chair that as Geoff (the president) was unable to attend. Toni will bring you up-to-date with any relevant details in her delegate's report.

I hope the lock-down did not cause too many problems for you and all stayed safe

Warm Regards

Dean

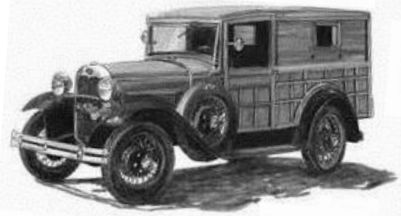
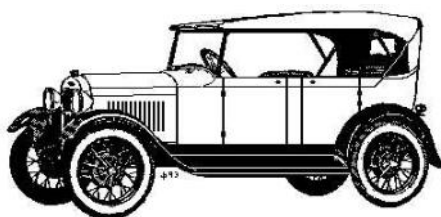

Inside This Issue

Note from the President	2
Secretary comments	3
Editor Comments	4
Wanted & Free	4
Events Coordinator	5
Classic Car Show	7
CMC Delegate's Report	8
Curtin Radio Car Show	9
North West Run Update	10
For Sale	10,14
Car Show Tour	11
Technical Tip	15
AIS for Code 404	16
Sponsors	17

SECRETARY COMMENTS

Kathleen Kuenzel (secretary@modelafordclub.com.au)

As I write this note we are once again in lock-down but fortunately only for 3 days. Hopefully the duration will stay at that short period and will not have an impact on the Winter Getaway which is due to start on 30 April. I'm sure that, with me, you wish the folk taking part in that venture a safe and enjoyable journey.

Another upcoming club event is the proposed North West run. I have heard from Wayne Millman that he has had to make a couple of changes to the timetable, one of which is due to the Kalbarri cyclone. All who have nominated for the run have been advised but he has requested that the information be more widely distributed in case there are others who wish to take part. I have asked our editor to add the details to this newsletter.

Please note: Edith Jeffree has shortened her email address to ejjeffree@bigpond.com The "au" has been dropped from the end.

Kathleen

May Birthdays

Jeff Blackman	Denise Liesch
Barrie Byers	David Mathwin
Elaine Gilberthorpe	Anne Millman
Alan Jeffree	Debra Paisley
Anthea Kelly	Janette Seinor

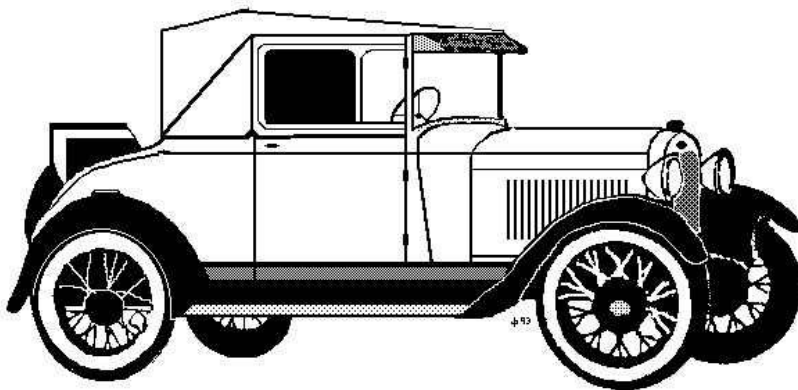

Western Model A News is the official newsletter of the *Model A Restorers Club of Western Australia Inc.*

Copy deadline 1st of each month to: maofwainc@gmail.com or **7 Gransmoor Way, Willetton WA 6155**

VIEWS EXPRESSED HEREIN ARE NOT NECESSARILY THOSE OF MARC of WA Inc.

MARCWA (INC.) CLUB CONTACTS

ELECTED:

President:	Dean Roberts	9295 2588
Vice-President:	Alan Jeffree	9275 4106
Secretary:	Kathleen Kuenzel	9385 3887
Treasurer:	Anne Steer	9457 4968
Committee Member:	Horace Misko	9256 1895
Committee Member:	Ian Steer	9457 4968
Committee Member:	Marilynn Horgan	9447 8237

APPOINTED:

Editor / Web site:	Ian Steer	9457 4968
Printer:	Daniel Pinnington	0400 132 445
Vehicle Registrar:	Kathleen Kuenzel	9385 3887
Events Coordinator:	Ray Mahony	9271 7630
Regalia Officer:	Marilynn Horgan	9447 8237
Librarian:	Dean Roberts	9295 2588
Spare Parts Officer:	David Bussard	9524 1086
Property Officer:	Ray Mahony	9271 7630
Delegate: CMC	Toni Mahony	9271 7630

Website: www.modelafordclub.com.au **MARC Email:** info@modelafordclub.com.au

MARC WA Life Members: Bill & Mavis Spencer (1987), Max & Dora Annear (2000), Ray & Toni Mahony (2004), Barrie & Gwen Guest (2006), Reg & Coral Blewett (2020), Alan & Edith Jeffree (2020), Steve Read (2020)

EDITOR COMMENTS

Ian Steer

editor@modelafordclub.com.au

The club spare parts list is now on the website. I have renamed the menu that used to be “Market” to “Parts”, and the spare parts list can be found under there.

There was a very interesting article in the March / April Restorer. I don't know about the rest of you, but when using a feeler gauge, I've never been certain *exactly* how much drag I should be feeling at the correct gap. The article describes the construction of a jig to hold the distributor, and then using a dial gauge to measure the point opening as the distributor is rotated. The article author found that he consistently got a gap 3 thou smaller than he wanted.

My original thought was that building the distributor stand (by someone with better fabrication skills than me) would be a good educational project for the club - we could all have a go and test our gap measuring ability and set up our distributors. However, I then thought of the practicalities of removing my distributor with its armoured cable. So I'm now turning my attention to buying myself a new “toy” (dial gauge with mag base) and doing this test with the distributor in-situ and using the crank handle.

WANTED

Model A - preferably Fordor or Tudor (for leg room), preferably licensed, in good condition. Fair price paid.

Daniel Pinnington 0400 132 445

Zenith 2 Carburettor, Lower section or whole carburettor.

Bill Daws, 0437-698-007 (NSW)

Various Parts, for a 1930 coupe that has been cut-down into a ute

- Headlight switch and fittings.
- Windscreen frame/ or complete one, stanchions, and nuts to suit.
- RH front door, front door hinges.
- Running boards.
- Front seat, frame or parts thereof.

Alan Lewis, Lakelands 0474 065 494, zlewis3@bigpond.com

FREE

AR wheel & tyre, 4.5mm of runout—Free to a good home within the club.

Contact Ian Steer, 0403 811 911

EVENTS COORDINATOR

Ray Mahony

events@modelafordclub.com.au

Thank you to the members who put their hand up to organise runs. The runs only happen if members do their bit - and remember assistance is always available.

Contact Ray Mahony

April/May

Event: MARC Winter Getaway

Dates: 30th April to 11th May

Organisers: Edith Jeffree & Toni Mahony

Anyone participating in this event will have been contacted by the organisers and are hopefully enjoying themselves.

May

Event: Northam High School Centenary Celebration

Date: Saturday, 15th May

Location: Northam High School Oval

Details: 10.00 to 3.00

Organiser: Contact Ray Mahony

Event: Monthly Run/meeting

Date: Sunday, 23rd May

Time: 8:30 for 9:00am start

Location: Stirling Square, Guildford

Details: Morning tea / coffee at York, then on to a farm at Youndegin (about 55km east of York)

Organiser: Daniel Pinnington

June

Event: Monthly Run/meeting

Date: Sunday June 27th

Details: to be advised

Organiser: Gary & Andrae Moore

June/July

Event: North-West Run

Date: 26th June - (approx.) 28th July

Details: See page 10 for an update

Organiser: Wayne Millman

Cont. over

EVENTS COORDINATOR (CONT)

Ray Mahony

August

Event: Monthly Run/meeting
Date: to be advised
Details: to be advised
Organiser: John Watson

September

Event: AGM
Date: Sunday 12th September
Location: VCC club rooms, 265 Hale Rd, Forrestfield
Details: 11am to 3pm
Organiser: Kathleen Kuenzel

27th Model A National Meet - 2022

Date: 11th-17th September, 2022
Location: Goulburn, New South Wales
Details: [National Meet 2022 Information Page](#)
Organiser: Model A Ford Club of New South Wales

Club-Sanctioned Events

Monthly

Event: LBW (Leeming, Bullcreek, Willetton) Coffee Run
Date: 1st Tuesday of every month (except January)
Time: 10am
Location: Ruby's Bakehouse, 1 Dundee St, Leeming
Organiser: Steve Seddon (VCC)

October

Event: All Ford Day
Date: Sunday 3rd October
Location: Steel Blue Oval, Bassendean
Details: On-line entries will open in May
Further details to follow

September 2022

Event: "RED DUST REVIVAL"
Date: 19th to 25th September
Location: Lake Perkolilli

CLASSIC CAR SHOW

Ray Mahony

Who could have wanted a more pleasant day for such an event, with the sun shining and a gentle breeze to keep us from over-heating. Our location was slightly different than last time; instead of being in the open we were nestled around large shady trees.

The club had 17 cars on display including John and Kay Cook's US-style Police car (complete with blue light and siren) which they brought down from Kukerin. Daniel Pinnington had his first official drive in a Model A when bringing Horace's Tudor to the park. There was plenty of room between each so the spectators could get a good look at each car. Horace's old "UTE" attracted much attention again, as usual. Hans had the tow truck advertised for sale, but apparently only attracted "tyre kickers" and wishful thinkers.

At the club gazebo, Dean had the new "Model A" block and crankshaft on display for members to see and discuss. Glenda had a large selection of handiwork on display and for sale, and did very well by all accounts.

Reportedly, there were some 1000 cars on display throughout the Ascot grounds - slightly more than last time. The theme for the day was "Australian Made" with a special area designated for this. Alan Jeffree had his Phaeton in this area. Many others displayed the "Australian Made" card within their club display area.

I would say this year's display was the most pleasant we have had; being able to sit under the shade of trees, on a not too warm day and with good company, made the day pass very nicely.



MARC MAY ACTIVITIES IN YEARS GONE BY

10 Years Ago: CMC proposing changes to Code 404, Colin Davidson's run left early and Brett Pollock was left behind, the Jeffree's Dryandra excursion was described by Lorraine Piercy, Redmans welcomed to the club.

20 Years Ago: Kirup weekend described by Toni Mahony, Toowoomba meeting planning, mid-week run to Katrine, Gary & Rosalie Eva's story of their Adelaide-Tasmania-Perth trip in their roadster.

30 Years Ago: Car display at Whiteman Park, then another at the Gun Club during the World Shotgun Championship.

40 Years Ago: no newsletter in May.

CMC DELEGATE'S REPORT

Toni Mahony

A general meeting of the CMC was held on the 19th April at Eden Hill, with about 45 delegates in attendance. Our own Dean Roberts was chairing the meeting in the absence of Geoff Moor – and a darn good job he did, under trying circumstances. A few people reckoned it was the best meeting they'd ever been to!! (Trying to get his swollen head back to normal size!!).

The usual Council housekeeping business was attended to, with an inconclusive update of the Classic Car Show - due to it only being held the day before. Crowd and car numbers, takings and all of that will be forthcoming. However, it was felt that there were more cars than last year and the programs ran out at 1.00pm, so that must mean that maybe more people also came through the gate – why wouldn't you, it was a glorious day! However, they are still looking for someone to run this major show next year, with assistance forthcoming from the CMC.

As has been the case over the past year or so, the main topic of conversation was the Concessions, both 404 and C4C.

Now that C4C has been rolled out, we are waiting to see what ramifications or anomalies it throws up. The C4C information is on the Dept of Transport website, along with FAQs and all the appropriate forms – look under "Concessions". There are already one or two areas of concern, of which the DoT will be advised.

The negotiating group from CMC gave us a report on where they see problems occurring for 404 Concession holders. There will be another meeting with the DoT before the June CMC meeting – and some interesting points were raised which will be taken to that meeting. These include where our responsibilities as a Club are concerned.

The CMC Secretary's role is still officially vacant – any takers?? They are also looking for an IT person to help out with the roll-out of the Wild Apricot computer system.

On the federal scene, negotiations have recommenced with the federal government, (after stalling a bit during the pandemic), regarding the luxury tax on imported vehicles over 70 years old – we await what might come of this.

Next CMC General meeting will be held on 21st June.

CURTIN RADIO CAR SPECTACULAR

Jean Misko

Despite cyclone Seroja doing her best to disrupt the day, it went ahead as planned. A fun time was had by those Model A members that were able to attend and display their vehicles.

The judges for the day were from the Motor Museum and a Model A, "Rustored" was selected as Best Car at Show!

The Best Club Display was awarded to the Military section of the VCC, for their comprehensive display.



Horace's prize-winning Rustored, and Jeanie's Mustang



Moorehead's FB Holden and friend



Horace, Rustored & the trophy

JUNE/JULY NORTH WEST RUN

Wayne Millman

(Including Race rounds Marble Bar, Roebourne and Carnarvon)

NOTE: Due to Kalbarri having the Cyclone I have changed the run slightly.

Phone numbers of the suggested caravan parks are included.

- Departure 26th June – Return around 28th July
- 26th meet up at Bakehaus Bindoon 9.30am

- Perth to Paynes Find 390km O/N ph 99636111
- 27th Paynes Find to Karalundi 415km O/N ph 99812000
- 28th Karalundi to Newman 366km 2 nights ph 9172888
- 30th Newman to Meentheena 234km 2 nights ph 0497004491
- 2nd July Meentheena to Marble Bar 90km 2 nights ph 91761569
- 4th Marble Bar to Hedland 190km 3 nights ph 91722046
- 7th Hedland to Port Sampson 215k 4 nights ph 91870199
- 11th Port Sampson to Onslow 350km 2 nights ph 91846053
- 13th Onslow to Minilya Roadhouse 350km O/N ph 99485153
- 14th Minilya to Carnarvon 140km 5 nights ph 99418150
- 19th Carnarvon to Geraldton 476km 2 nights 99211997
- 21st Geraldton to Perth 414kms
- 22nd Perth to Collie 200km

There is approx. 170km of unsealed road between Newman and Marble Bar also approx. 70km unsealed between Highway to Onslow via Peedamulla road.

Staying at caravan parks along the way.

I understand everyone's circumstances are different.

Please feel free to do all or only part of the run.

FOR SALE

Balanced V8 modified **flywheel and pressure plate** to suit a Model A. Snyders Part Number A-6375-V8 Slightly used, as new, excellent condition; \$800.

Oil filter kit, Model A, new, Snyders part number A-6705-F. Only suits 15 inch drain tube, \$285.

Contact Hans Hurij , 0472 700 635

GREAT SOUTHERN CAR SHOW TOUR

Tania Piercy

Tis the season...

for car shows. The weather is supposed to be cooling off and a bit more comfortable for old cars and drivers alike. This hasn't really happened yet this year, but we've been busy touring just the same. Darryl has (mostly) finished building and fitting the truck with camper/cabin and workshop as well as custom trailer for Bert. We are set to travel!

We first went to Collie for VCCWA Collie branch's 'Sparkplugs on the Hill', held as part of the Collie Festival over the Labour Day long weekend.

Collie branch were kind enough to allow us to park up at the clubrooms in the heart of town where we were in walking distance to the events. Collie clubrooms are wonderful and make a great place for dinners and entertaining or simply sitting on the veranda having a sundowner. The Collians/Collie-ites/Collies are a friendly and active group, as travellers on Wayne's Jurien Bay to Koorda run will agree.



VCCWA Collie Clubrooms



Sparkplugs On The Hill, Collie

On a shake-down tour of Collie our career was nearly over before it even started! After passing through a set of lights (I should say, the only set of lights) a car came from a drive-way through a gap in the cars waiting for the lights and pulled straight in front of us! I didn't think Bert's brakes were all that good, but they did the trick (although Daz has been complaining of a sore foot since). Bert veered and skidded sideways, brakes squealed and there was such a universal gasp from onlookers that I felt momentarily lightheaded from lack

of oxygen. There we stopped door-handle to door-handle, close enough to reach over and tap politely on the window of the errant driver's passenger window. But, before Darryl could respond with the universal hand gesture for such situations, the silver-sedan-Collie-plates was off and everyone could breath again. Who knew a 45km/hr near-miss could be so dramatic, but it was, trust me.

The Collie club invited car groups from around the South-west to display their cars and there was a fantastic turnout with lots of interest in the vehicles. We spent a very enjoyable few days in Collie before heading off on the Monday as the rain set in. Big mistake.

We tell ourselves this every trip - DO NOT DRIVE



VCCWA Collie Clubrooms

Cont. over

CAR SHOW TOUR (CONT)

Tania Piercy

AROUND WA TOWNS ON A SUNDAY OR PUBLIC HOLIDAY. But we forget and soon find ourselves in a succession of closed-up towns without a single sign of life or service on offer. I wouldn't have been surprised to see tumbleweeds blowing down main streets, but it was too wet. We headed east where we sat for 10 minutes before a break in the traffic allowed us to turn right onto Albany Highway (Public Holiday Monday – remember). With thoughts of staying in Kojonup we headed south. Kojonup was jumping in comparison to other towns. Well, at least the bakery and public toilet was jumping; not much else was open.



Wellington Dam

After peering through closed doors in and around town we parked up in a nice spot by the old railway siding and planned how we would get dinner. Always a primary concern. Apparently the only 'dining' experience in Kojonup is the roadhouse on the outskirts of town or a take-away curry from the bakery. One pub has shut and the other "can't be bothered cooking any more". They stopped meals during COVID and decided they did very well with the bar and drive-through without the hassle of food, thank you very much. Disappointing for the town folks (who complained bitterly) and visitors. We took a soggy walk along the heritage trail, cooked at 'home' and went to bed.



Wellington Dam

We thought Mt Barker might be nice and it was. We intended to stay in the 24 hour RV parking across from the pub, but it was closed to travellers due to 'Risk of COVID'. This seemed an odd decision by council and when we asked locals they said that the caravan park out of town set up a petition and brow-beat local businesses into signing to have it closed. So, we went to the caravan park instead, from where we could unload Bert and then drive into town for a pub dinner. Nope. Couldn't fit, mostly booked out,

low hanging trees everywhere, unhelpful battle-axe behind the counter (source of the petition for sure) and we drove back north to Cranbrook. Brilliant! Lovely little town with 3 cafes and a pub all doing dinners (Hello Kojonup. Anyone listening?) Caravan Park extremely helpful and friendly. All things you hope to find in a (very) small country town.

Next day was Dumbleyung where we spent some happy hours snooping around town and brushing up on the history of Donald Campbell and Bluebird. Great little museum where you ring a phone number for the secret code to let yourself in and browse to your heart's content. I think that's called "work

Cont. over

CAR SHOW TOUR (CONT)

Tania Piercy

smarter, not harder". Stayed in another RV park in town. Let me tell you, Dumbleyung know what they are about. The RV park is on the oval just beside town. The council has put in a gravel path with solar night lighting all the way to the pub door! Now that's thinking. We didn't fall in a ditch, river or turn an ankle on a dark roadside once! Still raining.

Thursday and we drove on to Kukerin to shamelessly bludge off Johnno and Kaye Cook with whom we had arranged to drive to the Wagin Woolorama on Friday. The last 5km to their farm is gravel and you should have seen the state of Bert on the trailer when we arrived. Red mud from end to end! Washed Bert, washed ourselves, reacquainted ourselves with cars (hmmmmm seems to be a few more than last



Dumbleyung

time....and does this shed seem bigger than before?) and collections, spent 45 minutes looking for Kaye's phone and then it was time to put our feet under the table, from where we didn't move much at all.

Friday, and we drove both Tudors across to Wagin where the VCC Central & Upper Great Southern branch had a display in the Historical Village adjacent to the showgrounds and Woolorama. Much like every agricultural show, we soon found ourselves sampling a vast array of wine and gin before 11am and eating stuffed spuds for lunch before killing time until it's



muddy Bert

reasonable to drive home again. Thankfully, the local constabulary are either short sighted or inattentive. They did not book either of the speeding Tudors going 80+ through a road-work zone on the way home. Phew! Oldest cars ever to be crushed for hooning??? Another great night with our feet under the table at Dingo Dell before heading home.

I had intended to write about our trips to Esperance's 'Outta the Shed' and Northam's 'Motorsport Festival', but I've run out of steam and will leave that pleasure to another time.



Woolorama

FOR SALE

Are you looking for a unique A Model Ford?

This is a rare opportunity to acquire one that is outside of a standard pickup. Would make great a advertising vehicle for a towing company, mechanical repair shop, panel beater repairs, etc - or just drive as a Model A.

This is a Model A Ford, 1928 Closed Cab Pickup. It has bucket seats and seatbelts. This vehicle has wind-up windows with extra cab dimensions for the largest driver. Vehicle vintage tow crane is installed to timber rear tray. The crane was manufactured by APAC Adelaide and approximates period correctness. Crane is removable to enable vehicle to be used as a standard Pickup. All metal body, good rubber, stainless front and rear bumpers, turn indicators, air shock absorbers, private plates "1928TOW" go with the vehicle, owner has license to trade. Concessional 404 license not transferable outside club membership WA.

Can deliver anywhere in WA at extra cost.

Contact - Hans Hurij, MARC of WA

mob: 0472 700 635. email: tricka3@bigpond.com

It is a recent restoration that is still being run in, vehicle has new A Model engine including:

1. Dynamic-balanced crank , flywheel and pressure plate.
2. New clutch plate.
3. Machined / lightened flywheel. New ring gear installed.
4. Re-ground crank, big ends & mains.
5. Rods re-metaled.
6. New gudgeon bushes.
7. New pistons (0.080").
8. Re-bore and hone cylinders.
9. New rings.
10. New B water pump and nylon fan.
11. Model B high compression head, tested, planed and sealed.
12. Re-ground Camshaft 0.330" lift.
13. Aluminium timing gear.
14. Modern adjustable valve lifters and guides.
15. O/size Modern 1 3/4" intake valves and std size exhaust valves.
16. PCV valve installed.
18. Pressure tested block and head prior to rebuild.



TECHNICAL TIP

John Moorehead (re-print from Western Model A News, Feb 2002)

Keeping Lubricant in a Model A Steering Box

Like many Model A's, our phaeton suffered from lubricant leaking from the steering box even though the bushes are in good condition. Whilst the amount of lubricant over a period of weeks only amounted to a few drops - it was annoying.

A fellow club member, (John Forbes) advised that he had solved the problem with new bushes and a spring loaded felt washer positioned adjacent to the frame. I tried the felt washer with limited success.

Whilst lying on my back studying this problem, it was noted that approx. 1/8" of round shaft protruded from the steering box through the frame before the square section. I removed the two securing bolts holding the steering box to the frame and applied gasket sealant between the steering box and frame. A standard two lip oil seal was placed over the shaft and against the outer side of the frame. Again, some gasket cement was placed between the outer part of the seal and frame. A spring and thrust washer was positioned between the seal and pitman arm (see sketch).

After some months and several hours the steering box remains free of leaks!! Whilst this technique is not as sound as removing the steering box and machining the box to take a special seal, for just a few dollars my problem was solved!!

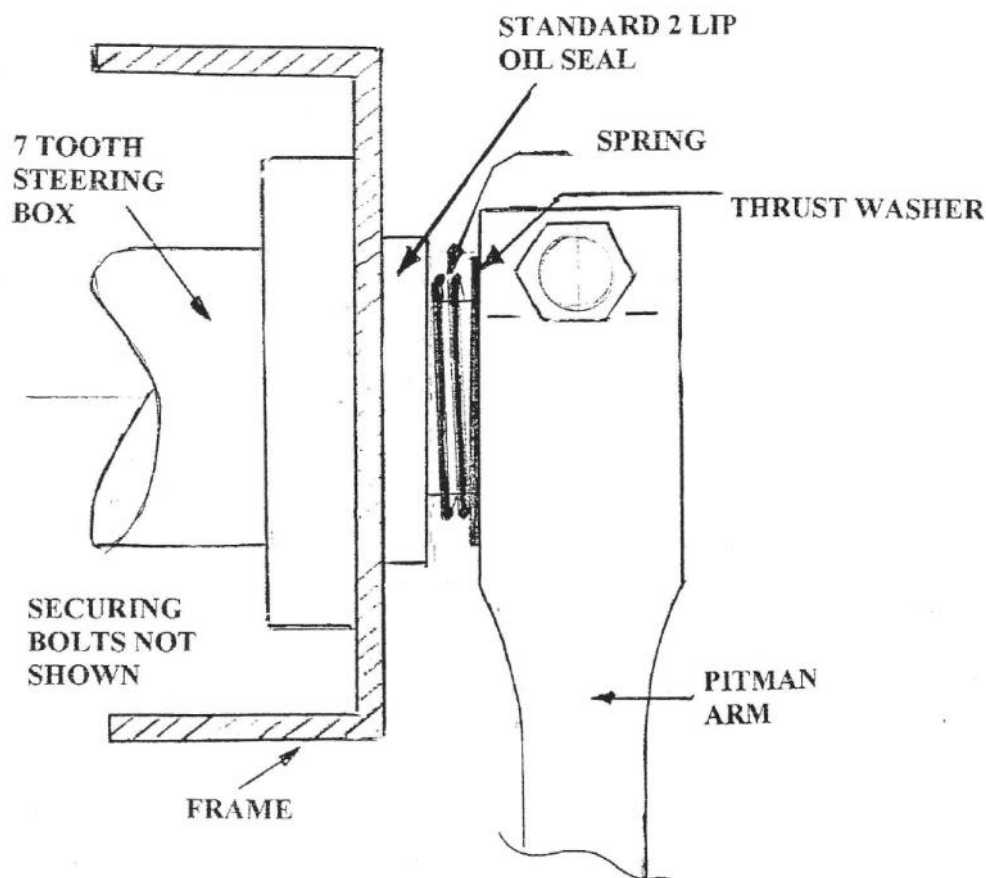

INSPECTION STATIONS FOR CODE 404

John Moorehead

Regional WA			
Vintage & Classic M/C Club *	105 Home Rd. Robinson, Albany, 6331	0418900626	Colin Dowsett
Veteran Car Club, Albany	Club Rooms, Kitson Rd., Albany, 6331	(0429457086	Phillip Astill
Indian Harley Club *	14 South West Hwy, Boyanup, 6237	(08) 97315406	Murray Rudler
S/W Veteran Car Club	L84 Mummery Cres., Bunbury, 6231	(08) 97212361	Peter May
Metropolitan Area			
Tractor Museum	Motor Museum Whiteman Park, 6068	0428946934	Laurie Doncon
MGTC Owners Club	3/77 Bickley Rd., Cannington, 6107	0413045772	Colin Bonney
Veteran Car Club of WA	205 Bailey Rd., Glen Forrest, 6071	0431929684	David Reid
WA Omnibus Group	51 Albert Rd., Middle Swan, 6056	0407924475	David Churn
Jaguar Car Club of WA	14 Kalmia Rd., Bibra Lake, 6916	0466791298	Ian Maitland
Veteran Car Club of WA	53 Hennessy Av., Orelia, 6167	(08) 94193149	Richard Beazley
Veteran Car Club of WA	265 Hale Rd., Wattle Grove, 6107	0457154440	Murray Lizatovich
Veteran Car Club of WA	265 Hale Rd., Wattle Grove, 6107	(08) 9252 1292	Phil Stockdale
Veteran Car Club of WA	265 Hale Rd., Wattle Grove, 6107	0417189475	John McLean
Vintage Motor Cycle Club *	11/25 Hanson St Maddington, 6109	0419907688	Phil Skinner

NOTE 1. The above examiners and authorised premises are appointed by the Department of Transport to examine vehicles for licensing purposes for Class B Concession Type Code 404.

NOTE 2. Vehicles being licensed for concession Code 404 Class B can also be examined at a DoT examination centre or at an Authorised Vehicle Examination Centre. Motor vehicles from Jan. 1970 and motor cycles from July 1975 not previously licensed in Australia can only be inspected at a DoT Authorised Examination Centre.

NOTE 3. The above AIS /AVE are approved for the examination of light vehicles only, i.e. less than 4500kg GVM. AIS marked with an * (Asterix) examine motor cycles only. WA Omnibus Group AIS 167 U is for the examination of cars and heavier vehicles.

NOTE 4. It is essential that individual AIS/AVE personnel are contacted prior to an examination to arrange an appointment.

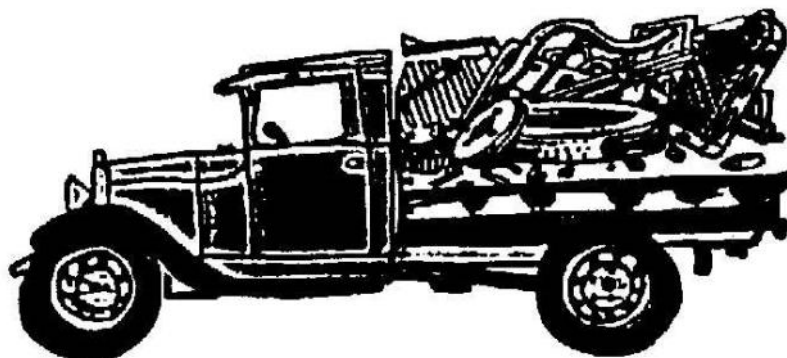

MEMBER'S CAR STORIES

Read the story behind Peter & Kaye Eardley's 1930 Fordor :

<http://modelafordclub.com.au/wp-content/uploads/memberscars/Peter-Eardley-fordor.pdf>

SPONSORS

PLEASE SUPPORT OUR VALUED SUPPLIERS

RAY ABBOTT ENGINE RECONDITIONING

"RECONDITIONING THE PAST"

SPECIALISING IN VETERAN, VINTAGE & CLASSIC ENGINES

61 YEARS EXPERIENCE: IN BUSINESS FOR 48 YEARS



CYLINDER HEAD SERVICING, REBORING, RESLEEVEING, CONROD
RESIZING & BUSHING, LINE BORING & REMETALLING
CRANK REGRINDS, PRESSURE TESTING, PISTON GRINDING &/OR
EXPANDING, CAMSHAFT GRINDING .
COMPLETE ENGINE REBUILDS

18 Rio Street, Bayswater

PHONE 08 9272 4566

Rebuilding Oldies Better Than New

Recommended by MARCWA members

Henry's

**FORD
MODEL T & A
PARTS**

Keith & Glenys Eastwood
129 Balance Road
Ballan 3342
VICTORIA, AUSTRALIA

Ph (03) 5368 1088

Fax (03) 5368 1007

Mobile 0402194723

kg@henryspares.com.au



Cont. over

**VETERAN, VINTAGE, CLASSIC
LUBRICANTS & ELECTRICAL**

Halogen Bulbs 6v & 12v Tungsten Bulbs 6v & 12v Indicator Stalks
 Flasher cans 6v & 12v Tail lights Indicator Lights (over 30 different
 types)
 Fuel Pumps 6v & 12v Wiper Motors 6v & 12v Wiper Blades
 Cables (Cotton Covered, Metal Covered, PVC)
 High Tension Cable (Cotton Covered, Black PVC)

Spark Plugs 19" and 21" Model A Tyres Tubes Rust bands
and All Things Vintage



Under New Ownership!
 Changed our name and we've moved!



PH (08) 9274 2066

<https://yesteryearparts.com.au/>

Visit us at
ULTRALUBE
 MECHANICAL WORKSHOP

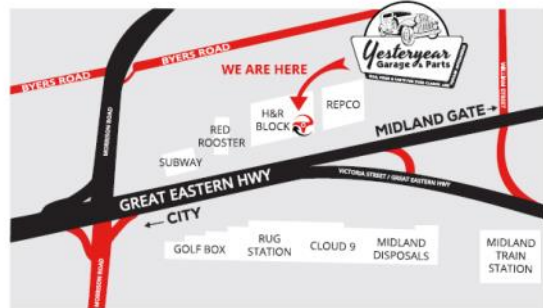

We are conveniently located at
 3/350 Great Eastern Hwy Midland

✉ parts@yesteryearparts.com.au

**EARLY
FORD
PARTS**



Specialising in New Old Stock and
 Reproduction 1909 - 1948 Early Ford Parts.

Dave Slater

- ✉ dave.slater@casmn.com
- ☎ 0412 59 3535
- 🌐 We post Australia-wide
- 🏠 5 Chauncey Court, Wodonga VIC 3690