

# Western Model A News

VOLUME 42, ISSUE 3

MARCH 2021



**Model A Restorers Club of Western Australia, Inc.**



## NOTE FROM THE PRESIDENT

**Dean Roberts**

[president@modelafordclub.com.au](mailto:president@modelafordclub.com.au)

Over the weekend we had our last run/meet for summer at Sandy Beach Reserve. Even though it was a long weekend, it was good to see so many people there enjoying the morning.



During March, the MARC of WA club committee will be getting together to discuss the introduction of the new C4C registration concession and how to introduce it into MARC of WA in-line with the goals of our club. It is hoped we can have something ready for the next run/meet to present to the meeting and if accepted, give MARC of WA a direction to move forward with.

As a reminder, there has been no change to 404 concession at this time and it will stay as is until April 2022. During this time, please make sure you keep to the 404 rules. This reprieve was largely due to the support we got from you, and members of every car club in Western Australia, writing to our politicians and voicing our objections to the proposed changes to 404. There is still a lot of work to do between now and April next year to try and keep the 404 rules as they are now (or at least to minimal change). We will keep you posted.

Hope to see you on the next run, in the meantime stay safe.

Dean Roberts



### Inside This Issue

<b>Note from the President</b>	2
<b>Secretary comments</b>	3
<b>Editor Comments</b>	4
<b>CMC Delegate's Report</b>	4
<b>Events Coordinator</b>	5
<b>MARC Winter Getaway</b>	8
<b>Feb Run Report</b>	9
<b>North-West Run</b>	11
<b>Alex Kirkwood Story pt1</b>	12
<b>Technical Tip</b>	15
<b>DIY Car Painting</b>	16
<b>Sponsors</b>	17



**Front Cover:** Reg & Coral Blewitt after presentation of their Life Member certificates and badges



# SECRETARY COMMENTS

**Kathleen Kuenzel** ([secretary@modelafordclub.com.au](mailto:secretary@modelafordclub.com.au))

It was great to gather at Sandy Beach Reserve on Sunday for our annual February meeting with the feeling that maybe this year we will manage to continue with monthly runs and meetings throughout the year. Of course, the same meeting last year was the last we managed before we had to shut down for a few months prior to arranging for some scattered gatherings as the year progressed. Hopefully we can round up our full complement of participants once more and return to normal.

I have heard from a couple of members who are either changing details of a vehicle or licensing a new acquisition. Please keep me informed of whatever changes you make to your details.

Kathleen Kuenzel

## March Birthdays



Elizabeth Calhoun	Lorraine Steele
Frank Farrelly	Lachlan Steele
Evan Gobby	Cerena Stratford
Shirley Hall	Sue Swindell
Tom Hart	Gerard TenBokkel
Alex Kirkwood	Pamela TenBokkel
Rob Lazenby	Matthew White
Rob Mawson	Steph Will
Daniel Pinnington	

**Western Model A News** is the official newsletter of the *Model A Restorers Club of Western Australia Inc.*

**Copy deadline** 1st of each month to: [maofwainc@gmail.com](mailto:maofwainc@gmail.com) or **7 Gransmoor Way, Willetton WA 6155**

**VIEWS EXPRESSED HEREIN ARE NOT NECESSARILY THOSE OF MARC of WA Inc.**

### MARCWA (INC.) CLUB CONTACTS

#### ELECTED:

President:	Dean Roberts	9295 2588
Vice-President:	Alan Jeffree	9275 4106
Secretary:	Kathleen Kuenzel	9385 3887
Treasurer:	Anne Steer	9457 4968
Committee Member:	Horace Misko	9256 1895
Committee Member:	Ian Steer	9457 4968
Committee Member:	Marilynn Horgan	9447 8237

#### APPOINTED:

Editor / Web site:	Ian Steer	9457 4968
Printer:	Daniel Pinnington	0400 132 445
Vehicle Registrar:	Kathleen Kuenzel	9385 3887
Events Coordinator:	Ray Mahony	9271 7630
Regalia Officer:	Marilynn Horgan	9447 8237
Librarian:	Dean Roberts	9295 2588
Spare Parts Officer:	David Bussard	9524 1086
Property Officer:	Ray Mahony	9271 7630
Delegate: CMC	Toni Mahony	9271 7630

**Website:** [www.modelafordclub.com.au](http://www.modelafordclub.com.au)

**MARC Email:** [info@modelafordclub.com.au](mailto:info@modelafordclub.com.au)

**MARC WA Life Members:** Bill & Mavis Spencer (1987), Max & Dora Annear (2000), Ray & Toni Mahony (2004), Barrie & Gwen Guest (2006), Reg & Coral Blewett (2020), Alan & Edith Jeffree (2020), Steve Read (2020)

---

# EDITOR COMMENTS

---

Ian Steer

[editor@modelafordclub.com.au](mailto:editor@modelafordclub.com.au)

We have now setup “official” email addresses for key positions in the club. This not only looks more professional, but it means when the people in these key positions change, the email address will remain the same (eg you’ll always be able to use [president@modelafordclub.com.au](mailto:president@modelafordclub.com.au) to email the “president-of-the-day”). It also means that if anyone is on an extended holiday, or indisposed for a period, the email address can be re-directed to a stand-in person.

Our website address is [www.modelafordclub.com.au](http://www.modelafordclub.com.au), and all the email addresses end the same way (ie with “[@modelafordclub.com.au](mailto:@modelafordclub.com.au)”).

The email addresses that have been created are:

President	<a href="mailto:president@modelafordclub.com.au">president@modelafordclub.com.au</a>
Secretary	<a href="mailto:secretary@modelafordclub.com.au">secretary@modelafordclub.com.au</a>
Treasurer	<a href="mailto:treasurer@modelafordclub.com.au">treasurer@modelafordclub.com.au</a>
Editor	<a href="mailto:editor@modelafordclub.com.au">editor@modelafordclub.com.au</a>
Events Coordinator	<a href="mailto:events@modelafordclub.com.au">events@modelafordclub.com.au</a>
General club contact	<a href="mailto:info@modelafordclub.com.au">info@modelafordclub.com.au</a>

---

## CMC DELEGATE'S REPORT

---

Toni Mahony

A general meeting of the CMC was held on 15<sup>th</sup> February, and was the biggest I have attended. The main issue discussed was the ongoing saga of C4C and 404 concessions. The C4C for modified vehicles has effectively been bedded-down now with a commencement date of mid April. The 404 Concession will be reviewed over the next 12 months, in consultation with the CMC’s negotiating team and others.

A small group of car clubs proposed to continue the pressure on the Department of Transport by various methods, insisting no changes are to be made to the 404. However, after much vigorous discussion, this issue was voted upon with the result being in the negative. There is not much point in protesting something when we don’t yet know what the DoT has in mind regarding changes to the current system. While we would all like no changes to happen to 404, we know that there will be some changes - but are trying to keep them to a minimum. An additional person has been added to the negotiating team to bolster their expertise.

A proposed **foundation** (or similar) is in the early stages of being set-up using CMC funds. The aim of the foundation will be to promote motoring pursuits/interest amongst the young. The legalities and tax options are currently under review and discussion.

A re-enactment of the Australian leg of the 1968 **London to Sydney Marathon** will commence from Whiteman Park on 28<sup>th</sup> October 2021.

The **Classic Car Show** will be held on the 18<sup>th</sup> April at Ascot. If you are planning to attend with your Model A, please get in touch with Ray Mahony ASAP.

---

# EVENTS COORDINATOR

---

Ray Mahony

([events@modelafordclub.com.au](mailto:events@modelafordclub.com.au))

## URGENTLY NEEDED

**Members required to organise monthly runs for April, May, June, July and so-on for the rest of the year.**

Contact Ray Mahony

### March

**Event:** Coffee Run

**Date:** Wed 17<sup>th</sup> March

**Time:** 10am

**Location:** Mid-Century Café & Collectibles, corner Michael St & Knight Ave, Yokine

**Details:** To ensure we have a big-enough table, please let Alan or Edith know if you are coming by Wed 10<sup>th</sup> March

**Organisers:** Alan & Edith Jeffree

---

**Event:** Monthly run & meeting - a 40<sup>th</sup> anniversary re-run of the first MARC run held in 1981

**Date:** Sunday 21<sup>st</sup> March

**Time:** 10am for 10:30am departure

**Location:** Taylor St, McCallum Park, South Perth (heading to Mundaring via John Forrest National Park)

**Details:** A short run (about 1 hour) with no morning tea stop

**Organisers:** Anne & Ian Steer

---

### April

**Event:** Monthly run & meeting

**Date:**

**Organiser:** **\*\*Organiser wanted\*\***

---

**Event:** CMC Classic Car Show

**Date:** 18<sup>th</sup> April - 10.00am to 3.00pm

**Location:** Ascot Race Course

**Details:** <https://www.facebook.com/events/628317134503320>

**Organiser:** Council of Motoring Clubs

**MARC Coordinator:** Ray Mahony

**Anyone planning to attend must register themselves at:**

<https://www.trybooking.com/BNBNN>

**Please let Ray Mahony know you are planning to attend.**

Cont. over

---

# EVENTS COORDINATOR (CONT)

---

Ray Mahony

## April

- Event:** Curtin Radio Car Spectacular  
**Date:** 11<sup>th</sup> April  
**Location:** Trinity College Playing Fields  
**Details:** Entry from 6.30 to 9.00 **(No departure before 3.00pm)**  
**Organiser:** See Horace Misko for more information.

## April/May

- Event:** MARC Winter Getaway  
**Dates:** 30<sup>th</sup> April to 11<sup>th</sup> May  
**Location:** Pioneer Village car park, Armadale  
**Details:** See February newsletter for details, and page 8 for an update  
**Organisers:** Edith Jeffree & Toni Mahony

## May

- Event:** Northam High School Centenary Celebration  
**Date:** 15<sup>th</sup> May  
**Location:** Northam High School Oval Trinity College Playing Fields  
**Details:** 10.00 to 3.00  
**Organiser:** Contact Ray Mahony

## June/July

- Event:** North-West Run  
**Date:** 26<sup>th</sup> June - (approx.) 24<sup>th</sup> July  
**Details:** See page 11 for details  
**Organiser:** Wayne Millman

## September 2022

- Event:** 27<sup>th</sup> Model A National Meet  
**Date:** 11-17<sup>th</sup> September  
**Location:** Goulburn, New South Wales  
**Details:** [National Meet 2022 Information Page](#)  
**Organiser:** Model A Ford Club of New South Wales

## Club-Sanctioned Events

### March

- Event:** Classic Cars & Coffee  
**Date:** 28<sup>th</sup> March 8.30 to 10.00  
**Location:** UWA Business School Car Park  
Hackett Drive, Crawley  
**Details:** \$10 entry per car

Cont. over

# EVENTS COORDINATOR (CONT)

Ray Mahony

## March (cont'd)

**Event:** NZ National Model A Ford Rally  
**Date:** 28<sup>th</sup> March - 4<sup>th</sup> April 2021  
**Location:** Gisborne, NZ  
**Details:** gisbornemodelafordrally@gmail.com

## April

**Event:** Easter Rally  
**Date:** 2<sup>nd</sup> to 4<sup>th</sup> April  
**Location:** Albany  
**Details:** contact jensinclair@gmail.com  
**Organiser:** Veteran Car Club of W.A.

## Monthly

**Event:** LBW (Leeming, Bullcreek, Willetton) Coffee Run  
**Date:** 1<sup>st</sup> Tuesday of every month (except January)  
**Time:** 10am  
**Location:** Ruby's Bakehouse, 1 Dundee St, Leeming  
**Organiser:** Steve Seddon (VCC)

## September 2022

**Event:** "RED DUST REVIVAL"  
**Date:** 19<sup>th</sup> to 25<sup>th</sup> September  
**Location:** Lake Perkolilli



I'm not sure what motor it is running, but it has a Model A grille and front axle by the look of it. Note the tow hitch on the front, presumably to get it to and from the track. (Ron Andrews)

---

# WINTER GETAWAY UPDATE

---

**Toni Mahony**

A 'shakedown' and mapping run was completed last week by the organisers. This should be a fun, relaxing, but reasonably long trip over the 12 days, with the emphasis of staying off the main roads and highways as much as possible. You will see a great deal of 'bush' along the way, but hopefully avoid the large log trucks and traffic. This run will be held over 2 weekends and the week between.

At this stage there are 13 entries, with several of those joining us for a weekend or along the way for part of the route. There are several lone drivers, so if anyone would like to come along and act as navigator/companion, please let us know.

If you haven't already booked your accommodation, do it soon to avoid disappointment. See February club newsletter for more details on accommodation ([click here to see February newsletter](#)).

## **Current participants:**

Peter & Lorraine **Sartori**, Hans & Glenda **Hurij**, Wayne & Anne **Millman**, Ray & Toni **Mahony**, Alan & Edith **Jeffree**, Bob & Marilyn **Horgan**, Gerry **Ten Bokkel**, Ian & Anne **Steer**, Hamish & Dot, Tony & Pam (two families from Collie), Peter & Kaye **Eardley**, Neville & Sue **Swindell**

**Contact** Edith Jeffree or Toni Mahony for any further information.

---

## **Potentially interesting items out there on the web**

Model A running on charcoal: <https://www.youtube.com/watch?v=g22U79seuNO> (What is the 2<sup>nd</sup> radiator for?)

## **Australian Weekly Zoom Meeting**

Did you know there is a "Ford & Friends" weekly Zoom meeting originating in Australia?

Join us for our weekly virtual happy hour. Nothing specific planned, so bring any photos or stories and share with the group. Maybe we'll get another story from Mike Spencer about his misspent early adult life.....

Date and Time: Thursday at 2:00pm PST, 4:00pm CST, 5:00pm EST, 10:00pm GMT, Friday morning in Australia.

Hope to see you there,  
Rob

Zoom Information:

Topic: Ford and Friends Weekly Virtual Happy Hour

Time: This is a recurring weekly meeting.

<https://us02web.zoom.us/j/81149433413>

Meeting ID: 811 4943 3413

---

# MEMBER'S CAR STORIES

---

Read the story behind Peter & Kaye Eardley's 1930 Town Sedan :

<http://modelafordclub.com.au/wp-content/uploads/memberscars/Peter-Eardley-Town-Sedan.pdf>



# SANDY BEACH BREAKFAST RUN

Ian Steer



The annual Sandy Beach Reserve breakfast meet (organised by Anthony & Debbie Gilberthorpe in the family tradition) scored a fine and temperate morning for the last day of summer. About 40 members and 13 Model A's (one with a V8!) turned-up for the occasion, with a couple of cheeky moderns parking amongst them. Much barbequing of very aromatic breakfasts occurred - to make those of us that just brought cereals regret their decision.

During the meeting that followed, Alan Jeffree (the only new Life Member present) was presented with his Life Member's certificate and badge. Existing Life Members, Ray & Toni Mahony were presented with new Life Member's badges.



Dean presenting Alan Jeffree with his Life Membership certificate

Cont. over



# SANDY BEACH BREAKFAST RUN (CONT)

Ian Steer



Ray & Toni Mahony being presented with new Life Member's badges



The meeting under-way

# NORTH-WEST RUN

## Wayne Millman

This run takes-in the annual “race-round” events at Marble Bar, Roebourne and Carnarvon (for the atmosphere, rather than the actual horses).

We will be staying at caravan parks along the way. I understand everyone's circumstances are different, so please feel free to do all or only part of the run. I will be taking my little dog Molly.

The proposed itinerary is:

- Departure 26<sup>th</sup> June
- Return around 24<sup>th</sup> July
- 26<sup>th</sup> Meet up at Bakehaus Bindoon 9.30am. Perth to Paynes Find 390km O/N
- 27<sup>th</sup> Paynes Find to Karalundi 415km O/N
- 28<sup>th</sup> Karalundi to Newman 366km 2nights
- 30<sup>th</sup> Newman to Meentheena 234km 2nights
- 2<sup>nd</sup> July Meentheena to Marble Bar 90km 2nights
- 4<sup>th</sup> Marble Bar to Hedland 190km 3nights
- 7<sup>th</sup> Hedland to Port Sampson 215k 4nights
- 11<sup>th</sup> Port Sampson to Onslow 350km 2nights
- 13<sup>th</sup> Onslow to Minilya Roadhouse 350km O/N
- 14<sup>th</sup> Minilya to Carnarvon 140km 4nights
- 19<sup>th</sup> Carnarvon to Kalbarri 440km 2nights
- 21<sup>st</sup> Kalbarri to Geraldton 155km 2nights
- 23<sup>rd</sup> Geraldton to Perth 414km O/N
- 24<sup>th</sup> Perth to Collie 200km.

There is approximately 170km of unsealed road between Newman and Marble Bar, and also approximately 70km unsealed between NW Coastal Highway and Onslow via the Peedamulla Road.

At the time of going to press, there are 5 confirmed vehicles:

- Myself and my little dog - Model A ute
- Peter & Kaye Eardley - Model Fordor & teardrop caravan
- Kim & Janette Seiner - Model A Fordor with teardrop caravan
- Alan & Edith Jeffree - Model A ute and tent
- Tania Piercy & Darryl Freind

# ALEX KIRKWOOD'S A MODEL STORY PT1

Alex Kirkwood, Western Model A News, November 2006

The July issue of Model A News covered the story of an A Model in Derby and on reading this I felt inspired to write a few words in relation to an A Model that I grew up with. When I was studying for my Leaving Certificate in 1963, at age 17, my father had a serious talk to me and told me to focus on my studies and forget the A Model.... He then went on to say that I would grow out of this obsession that I had with the A ..... My father wasn't wrong very often, but in the latter phase of his life we still joked about that comment and how wrong it was. I have always had a deep passion for 28/29 A Models and maybe the story below will reveal the reasons why...so here goes.

## WHY AN A

As a member of the Model A Restorers Club, people may ask...why restore an A Model? In my case I didn't stand a chance.

I was born in 1946 in Boulder and at that time, my father had already owned an A Model for 7 years, having purchased "Lizzie" for 25 pounds in 1939.

Lizzie was in fact a tourer that had been converted to the Aussie ute style and was used primarily by my dad as transport to and from work in the mines, to collect wood from the bush and to cart gear in relation to a hobby of gold prospecting.

You will note that Lizzie is referred to as an A Model. My father and other guys of that era referred to A Models and I never heard the term Model A used in conversation, although Model A is clearly the American terminology.

I can remember the A from way back when I used to go with my father and grandfather to collect wood. I can still remember clearly that Lizzie had a huge ability to cart a lot of wood and I still remember the spring (which had extra leaves) laying almost flat on the diff housings, but we always got home. (I was in serious trouble when I was about 16 and broke that spring as a result of pushing the old girl a little too fast through a creek bed.)

After the war in 1948, Dad decided to have Lizzie's engine rebuilt and this was undertaken by "Jack Hehir's Ford House" in Kalgoorlie. The rebuild was extensive and I still have the original invoices which show the total cost to be 37 pounds. As an example, 4 new 30<sup>th</sup> O/S pistons cost 4 pounds, a set of 8 valves cost 2 pound 7 shillings and so the list goes on. I also have the Motor Spirit Consumers License together with some unused 2-gallon ration tickets relative to Lizzie. These were last used in February 1950.

As a kid, I can remember being out prospecting in the A and recall one occasion when we were travelling slowly along a bush track and my father was paying so much attention to a small goldmine that he got off course and hit a low tree stump. This rearranged the front axle and broke the bell housing where the radius rod attached. Some ingenuity got us home and the old girl was returned to working order ready for the next weekend. On another occasion, part of the original fan dislodged and put a small dent in the side of the bonnet. A 4 blade fan was then fitted.

Cont. over



# ALEX KIRKWOOD'S STORY (CONT)

Western Model A news, November 2006

From an early age I became quite passionate about the A and learnt to drive Lizzie at age 12 ....and it didn't take long to take off without stalling as if I did stall the engine, my father would simply hand me the crank handle.

As a young bloke I looked for every excuse to drive the ute and by the time license time had arrived, I was quite an experienced bush driver....but things were a little different in Boulder in the 1960's.

At age 16 while in Perth I purchased a Floyd Clymer publication titled "How to Restore the Model A Ford". At that time I began to tidy the A which included painting the engine green and painting the front and back axles silver...which was the "in" thing at the time. I also added some stripes to the radiator shell, but I was overruled on that and had to repaint the shell. This was clearly the beginning of a restoration bug.

For my leaving certificate (ATAR) mechanical drawing project, I prepared a series of drawings of an A engine. The scales were taken from the above mentioned book and an old engine block that I had acquired. I still have these drawings and they even show Lizzie's engine number (CA 47519).

The leaving certificate was an interesting exercise as I was so taken with the A that I was continually told to forget Lizzie and concentrate on my studies, but that was not easy. I even resorted to sitting in the shed in the old girl to quietly read my textbooks.

Once I turned 17 I was able to cruise the streets, but when the A ran into engine trouble, I convinced my father to purchase a B Model engine from a wrecker named Reg Adams in Kalgoorlie. We had this engine rebored and Dad taught me how to scrape white metal bearings and how to assemble the motor. I converted this engine to fit the A (I still have this engine)

and then purchased a better radiator for 10 bob (also still have) which allowed prolonged travel and we had fantastic fun wandering far and wide around the goldfields. The photos below with the 3 guys



With constant A passenger Mitzie.

# ALEX KIRKWOOD'S STORY (CONT)

Western Model A news, November 2006

(that's me in the overalls) was taken south of what is now Kambalda, but the road to get there at that stage was a rough gravel road called Celebration Road for part of the way and then a rough bush track. But despite our travels, we never broke down and always got home.

(to be continued)



South of where Kambalda now is, 1963



On a little used road, 1963

## TECHNICAL TIP

Dick Przywitowski (taken from *The AaaaOOOgah! LaFayette, Colorado* )

### An easy to make tool to seat a horn rod clip

This tool will help to seat the clip on the end of the horn rod, which can be frustrating and sometimes painful.

The tool is a short piece of 3/4" OD conduit about 1½" long. Cut with a hacksaw half way through the conduit vertically and horizontally, taking ¼ of the piece of conduit out. An optional plug can be inserted in the end of the tube to catch the clip if it falls. *Note: You may need to squeeze the half round portion a little to fit the spider.*

#### To use:

1. Move the light switch 90 degrees, so that the forks of the spider are horizontal.
2. Hold the horn rod down using a ruler or similar item.
3. Set the spring and the spider on the horn rod end and press the tube to expose the notch that the clip goes into.
4. Seat the clip using needle nose pliers or forceps.

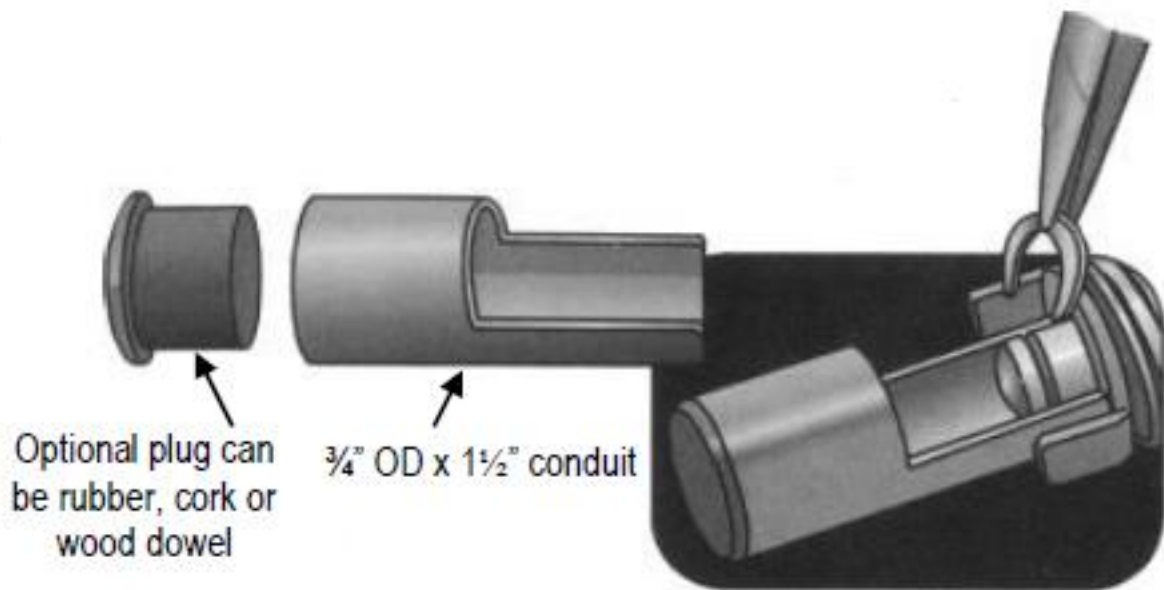

## MODEL A COMINGS & GOINGS

A prospective new member (Gavin) was at the Sandy Beach breakfast meeting. Gavin has an early 1928 AR coming from country Victoria, and will be only the 4<sup>th</sup> owner of the car. We look forward to seeing Gavin again.



# DIY CAR PAINT SHOP

**From:** Car Paint Hello <[hello@carpaint.com.au](mailto:hello@carpaint.com.au)>  
**Date:** Tuesday, 16 February 2021 at 11:29 am  
**Subject:** Spray Booth Welcome Offer (WA Car Clubs)

Dear Car Club Presidents (and car enthusiasts!),

For those of you who don't know us, we were **Autopower Car Paint Centre** (in Balcatta) and are a DIY car paint shop, now operating in our 43rd year.  
We've met a lot of you at the Classic Car Shows or Motorbike shows, or just from you popping in over the years.

We wanted to let you know that end of last year we moved down the road, changed our name to *That Car Paint Shop* & now have a bigger shop.

We also have an exciting development: a workshop with a WA-Made (Zodiac Semi Down Draft Bake Oven) Spray Booth that is ready for hire,  
PLUS we're running basic courses on how to spray, with advanced courses planned for the future. (Don't worry - we're still the same owners, with the same practical advice and many-years of knowledge.)

We'd like to offer your clubs a welcome offer where their first booth OR course booking will include a \$50 discount on any product they buy.

Our new details:

**New Address:** Unit 12, 30 Erindale Rd, Balcatta (next to the BBQ place)

**Opening Hours:** 8:30am - 5:15pm (Mon-Fri) or 8:30am-12pm (Sat)

**New Email:** [hello@carpaint.com.au](mailto:hello@carpaint.com.au)

**Phone:** 9345 3812

**Facebook:** [fb.com/thatcarpaintshop](https://fb.com/thatcarpaintshop) - follow us for all updates!

**Bookings:** for COURSE or SPRAY BOOTH hire - go onto [bookings.carpaint.com.au](https://bookings.carpaint.com.au) for all details & FAQs, or give us a call to book in.

**To Redeem Offer:** Book the booth or the course and let us know *which* car club you/they are from! We will automatically apply it when you come in :)

Please pass this information on to your club, and we hope to see you soon to help you with any project you have!

We won't be emailing you again as we don't want to intrude, so if you'd like us to tell you about upcoming courses, discounts & offers or you're happy to pass them on to your club - please let me know and I'll put you on our contact list.

Thank you,  
Amy & Nathan (that guy you normally see!)

That Car Paint Shop  
[fb.com/thatcarpaintshop](https://fb.com/thatcarpaintshop)  
[www.carpaint.com.au](https://www.carpaint.com.au)

Ph: 9345 3812

Email: [hello@carpaint.com.au](mailto:hello@carpaint.com.au)





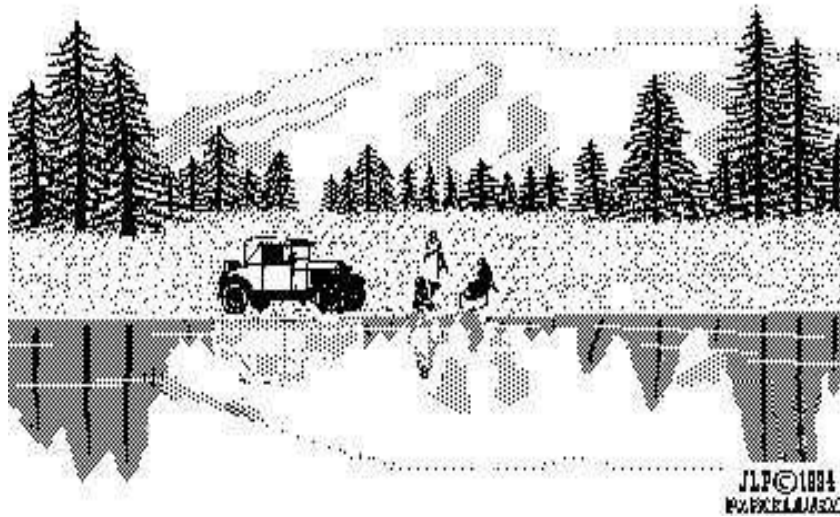

## SPONSORS

PLEASE SUPPORT OUR VALUED SUPPLIERS

### RAY ABBOTT ENGINE RECONDITIONING

**"RECONDITIONING THE PAST"**

**SPECIALISING IN VETERAN, VINTAGE & CLASSIC ENGINES**

**61 YEARS EXPERIENCE: IN BUSINESS FOR 48 YEARS**



CYLINDER HEAD SERVICING, REBORING, RESLEEVEING, CONROD  
RESIZING & BUSHING, LINE BORING & REMETALLING  
CRANK REGRINDS, PRESSURE TESTING, PISTON GRINDING &/OR  
EXPANDING, CAMSHAFT GRINDING .  
COMPLETE ENGINE REBUILDS

18 Rio Street, Bayswater

PHONE 08 9272 4566

*Rebuilding Oldies Better Than New*

**Recommended by MARCWA members**

*Henry's*

**FORD  
MODEL T & A  
PARTS**



Keith & Glenys Eastwood  
129 Balance Road  
Ballan 3342  
VICTORIA, AUSTRALIA

Ph (03) 5368 1088

Fax (03) 5368 1007

Mobile 0402194723

[kg@henryspares.com.au](mailto:kg@henryspares.com.au)

Cont. over

**VETERAN, VINTAGE, CLASSIC  
LUBRICANTS & ELECTRICAL**

Halogen Bulbs 6v & 12v Tungsten Bulbs 6v & 12v Indicator Stalks  
Flasher cans 6v & 12v Tail lights Indicator Lights (over 30 different types)  
Fuel Pumps 6v & 12v Wiper Motors 6v & 12v Wiper Blades  
Cables (Cotton Covered, Metal Covered, PVC)  
High Tension Cable (Cotton Covered, Black PVC)

Spark Plugs 19" and 21" Model A Tyres Tubes Rust bands  
*and All Things Vintage*



**Under New Ownership!**  
Changed our name and we've moved!



PH (08) 9274 2066

<https://yesteryearparts.com.au/>

Visit us at  
**ULTRALUBE**  
MECHANICAL WORKSHOP



We are conveniently located at  
3/350 Great Eastern Hwy Midland

✉ [parts@yesteryearparts.com.au](mailto:parts@yesteryearparts.com.au)

**EARLY  
FORD  
PARTS**



Specialising in New Old Stock and  
Reproduction 1909 - 1948 Early Ford Parts.

Dave Slater

- ✉ dave.slater@casmn.com
- ☎ 0412 59 3535
- 🌐 We post Australia-wide
- 🏠 5 Chauncey Court, Wodonga VIC 3690