



Western Model A News

INSIDE THIS ISSUE

Events - MARCWA	1
Events - Club & Others	2
MARCWA contacts	2
President's Report	3
March Meeting Report	4
Busselton Nationals—Roundup	5
Hubley Evening	6
Model A's in WA - 1930 Phaeton	7
Goldfields Trip	9
Electricity and Magnetism	10
Classifieds	11
Vehicle Examinations	12
Sponsors	13

NEXT MEETING

Event: April club run and meeting

Date: Sunday 26th April

Time: 0900am

Location: Fish market reserve off Swan Street, Guildford.

Destination: Araluen Botanic Park, 362 Croydon Rd Roleystone. Arriving about 10am. Back gates to park will be open for the club to place our cars onto the concourse. BBQ's and coffee house available.

Contact: Dean Roberts 040 891 3355

FOLLOWING MEETING

Event: June club run and meeting

Date: Sunday June 21st

Time: 0930hrs for a 1000hrs departure.

Details: Assemble at Stirling Square, Guildford. Destination Bailup Ford Farm, 10400 Toodyay Road, Bailup. 40km from Guildford to Ford Farm. \$10 per person entry (cash only), donated to PMH.

THE MAN WHO WILL USE HIS SKILL AND CONSTRUCTIVE IMAGINATION TO SEE HOW MUCH HE CAN GIVE FOR A DOLLAR, INSTEAD OF HOW LITTLE HE CAN GIVE FOR A DOLLAR, IS BOUND TO SUCCEED. -HENRY FORD



Please Note:

There is no meeting in May due to the following Club events in that month.

- Auto One Classic Car Show - Sunday May 3rd
- Vehicle inspections - Sunday May 10th



More Event Information

CLUB

Auto One Classic Car Show: May 3rd Sunday. Mussel Pool West. Club nominations for entry have closed but spectators can enter 10am—3pm. Gold coin entry.

Vehicle inspections: Are scheduled for Sunday May 10th, once again held at the VCC Club facility. Inspections are no longer required by the Transport Dept. But we offer it to our members on a voluntary basis. See page 12

Evedon Park, Burekup: April 3rd-7th Easter run to Evedon Park in Burekup The group leave on Good Friday. They meet at the Shell Service station on Thomas Rd just off the Freeway at 9am for morning tea then head south on the Freeway. Those going have received the details from Edith.

Cars and Coffee

Sunday May 24th, Midvale Speed Dome, Eddie Baron Drive, Midvale. 8am to 11am \$5 per car/bike \$10 swap meet bay. Spectators free

NON-CLUB

Event	All Australian Car Day	Vintage Automobile Association — Swap Meet	National Motoring Heritage Day	
Date	April 12	April 19	May 17	
Location	Waroona Show grounds	Polo Fields, Guildford	Nation wide	
Details	Display vehicles from 7am. Public entry from 10am	Vintage Car Swap meet.	Just get out there and drive your vintage car.	
Contact	http://www.shownshine.info/cswaaroaad.htm	http://www.vaawa.org.au/		

Western Model A News is the official newsletter of the *Model A Restorers Club of Western Australia Inc.*
Copy deadline 1st of each month to: maofwainc@gmail.com or 95 Boulton St Dianella 6059
VIEWES EXPRESSED HEREIN ARE NOT NECESSARILY THOSE OF MARC of WA Inc.

MARCWA (INC.) CLUB CONTACTS					
ELECTED:			APPOINTED:		
President:	Alan Jeffree	9275 4106	Vehicle Registrar:	Ray Mahony	9271 7630
Vice-President:	Colin Davidson	9495 4445	Editor:	Fred Manwaring	9475 0078
Secretary:	Kathleen Kuenzel	9385 3887	Property Officer:	Bob Newton	9341 5391
Treasurer:	Bob Piercy	9405 3766	Events Coordinator:	Ian Paisley	9456 1184
Committee Member:	Hans Hurij	9296 8744	Regalia Officer:	Fred Kuenzel	9385 3887
Committee Member:	Ian Paisley	9456 1184	Librarian:	Dianne Paisley	9456 1184
Website: www.modelafordclub.com.au					

Alan Jeffree

I commence with an apology for not being at the March outing and thank Vice President Colin Davidson for chairing the meeting in Waroona and Ashley Calhoun for organising the day! I was in the Goldfields with members, Brett Pollock, Bob Piercy and a group from Esperance VCC lead by Peter and Kaye Eardley. We had a great week and a short article and a few photos are further into this newsletter. I have also placed photos of this trip on our web page.

Members who were at the Waroona meeting will remember Colin asking for members who would be interested in formulating our Club position on Vehicle judging at National Meets. I would like to hear from members who would be prepared to meet and discuss our position. There was talk in Busselton at the State Delegate's meeting of dropping Concourse!

A reminder to all city members that vehicle inspections are being held at the VCC Club facility on Sunday 10th May, morning only. Details further into this newsletter. With Whiteman Park and vehicle inspections, both in May, there will be no Club meeting in May.

Rob Mawson is coordinating our Sunday 3rd of May Whiteman Park display and he will present those attending with their entry forms closer to the date. There is a list of those attending in the minutes accompanying this newsletter. One new name to add is Paul Kelly in his 1931 Special Coupe.

Throughout the year there are members who change address, phone numbers, email and these are published in our newsletters! If your details change, please let our Editor know so they can be published. Also important, is for members to ADD these changes to their Directories.

Our Easter Run to Evedon Park is all go and a leisurely programme has been planned. Friday we meet at the Thomas Road Shell Roadhouse for fuel and morning tea, before heading south to Burekup and Evedon Park. Saturday is a scenic drive into Bunbury, site seeing and stocking up on food for our few days. Sunday we drive to Collie to have morning tea with the Collie VCC, thanks to our Model A Collie members. While there we will view the open cut mine just east of the town. From Collie, accompanied by our two Collie families we will drive through Gnomesville, lunch at the St .Aidan's Winery before heading back to camp. Monday is a day of leisure at Evedon. Working members of the group will leave on Monday the rest driving home hopefully after the majority of the traffic has eased on Tuesday.

Some good news to complete my report! Beryl Paterson is now home with Alan after nearly two months in hospital following her serious accident.

Items to note on your Directories:

- Bob Piercy's new mobile and number – 0475 203 000
- John Laurie is best contacted on mobile – 0400 454 555
- Wayne Millman's correct email – waynemillman2013 @gmail.com

WAROONA MEET

Ian Paisley

WAROONA MEETING REPORT

Five Model A's and as many moderns started from Piney Lakes under threatening skies. Apparently some failed to properly read the run sheet and went in a different direction almost at the beginning. Somehow everyone managed to finish up at Mundijong for morning tea. Road works in the area didn't hamper our access to picnic tables so Mundijong turned out to be an ideal morning tea stop. Two more Model A's and two moderns joined the group here.

We were joined in Waroona by Wayne and Anne Millman, Neville and Sue Swindell all from Collie and Wes Hartley and Beverley Biggs from Busselton.

Everyone (30 people) managed to squeeze into the rotunda for lunch and meeting.

The weather was perfect!

Ten Model A's and several moderns finished up at the meet.

Ian Paisley

Waroona_Piney Lake starting point



Waroona_Centennial park



Squeeze into the rotunda



Waroona_Sth West Hwy en route

Round-Up

You may have travelled the world but you wouldn't have seen anything like Gnomesville!

As part of our Model A Meet we had a planned direction page to take members to visit Gnomesville which is just east of Dardanup.

There are a few web sites which give interesting fact and photos etc. Legend has it that the very first gnomes found his way to a hollow tree at this site!

The Easter Model Aers staying at Evedon Park will be having a stop there.

One of the interesting aspects of Gnomesville is the clever captions placed on the displays.

AJ



HUBLEY RACING

February Club Event

HUBLEY EVENING Saturday 7th February

Our annual Hubley racing was a successful night with a large number of Club members and a beautiful night to be out doors. Members arrived from 4.30pm onwards with racing commencing around five thirty.

Darren had enough spare models for all present to have an Hubley numbered for them.

Racing was close as usual with John Moorehead winning the night with a 3.762 from Nathan Roberts with 3.795 seconds.

The usual BBQ followed with sweets up to their usual excellent standard. Note Fred Manwaring's sweet bowl he brought on the bottom photo. I told him the sweets were worth coming for!! Many thanks to Darren for once again setting us up and conducting the races, and to our five grandchildren for doing the starting and loading the lanes etc!



The electronic recordings are shown on the TV screen. We time to the nearest one thousandth of a second and at times this is needed to separate the first and second cars.



John Watson is attracting the attention by doing some running repairs, which was needed quite often!



Spectators sitting and standing, watching the Hubleys.



Sweets time! Edith's ongoing birthday celebrations with a cake! Note Fred's Sweet bowl!

1930 Phaeton

Owned by Horace and Jean Misko 2009 –
 Owned by Eddie Wittington 1999? - 2009
 Colour: Maroon/burgundy with black
 Registration: SB 1930
 ENGINE NUMBER: CA 47229
 CHASSIS NUMBER: CAM 4789



In the spring of 2008, Horace and Jean attended the Floriade in Canberra, travelling with their caravan. Horace and Jean proceeded to Bega, NSW where they arrived at a caravan park at about the same time as Trevor and Nola Hooper, members of the Veteran Car Club of WA Inc. Trevor and Nola had come from Queensland with their caravan, and the two couples spent some time chatting. Of course, vintage cars were included in the chatting, and Horace said he would love to have a vintage car. He was thinking of a Model T. Trevor told Horace that there were a variety of vintage vehicles available in WA, and suggested that Horace join him at a Parts Shed morning – Trevor is a regular at the Wednesday morning working sessions held at the Parts Shed at the VCC's club rooms at Wattle Grove. The Hoopers were not returning to Perth immediately, but the arrangement was to be finalised when they did.

Horace joined Trevor at the VCC Parts shed on a Wednesday in November or December. He met Frank Cocks, a former member of the Model A Restorers Club of WA (Inc.), along with many of the regulars. He again expressed interest in a Model T, but was encouraged to look for a Model A instead. During January, the Parts Shed does not operate on Wednesday mornings to give the workers a break in the heat, but that year (2009) Horace went along to assist with some essential work. MARC of WA club member Ray Mahony was also helping, and Horace learned of the meeting to be held on Sunday 18th January at Manning Park.

Horace and Jean came along to the picnic meeting. Jean brought a book she was reading, but was persuaded to join in the fun and games instead. They sat with John and Helen Moorehead, and Kath and Kelvin Pepper, and say that they just felt that they belonged. The membership application form was completed on the spot, and they were inducted into the club that very day.

Horace and Jean did not realize that a Model A was not required for members to attend runs and meetings, so they did not attend for a few months. From Frank Cocks, Horace purchased a 1928 Ute/Utility which had been cut down from a Phaeton. Frank had put it together from various bits and pieces, mainly from the Parts Shed. It was nearly complete, but a ground up restoration needed to be done. Horace realised it would be a long process, so he spoke with John Moorehead, Alan Jeffree and other club members, to find a running Model A.



Classic Car Show at Whiteman Park

Horace and Jean's
1930 Phaeton



A run to Hillside Farm

1930 Phaeton—cont'd

The Miskos were fishing in Monkey Mia in May 2009 when they received a message from Alan Jeffree to contact Barry Bristow-Stagg about a 1930 Phaeton for sale in Northam. Horace contacted Barry and was given the name of the Phaeton's owner: Eddie Whittington, who worked at Dempsters Engineering in Northam. Unable to locate a personal phone number for Eddie, Horace phoned his workplace, leaving a message for Eddie to contact him. Eddie rang in the evening, and Horace and Jean went up the following weekend and liked what they saw. It had not been used for some time, only for the Whittington's son's wedding, and there was quite a bit of work to be done. They purchased it, returning the following weekend to pick it up. Eddie kindly provided a trailer to transport the Phaeton to Perth. Barry Bristow-Stagg will seek information from Eddie Whittington about his purchase of the Phaeton. Club member Steve Read thinks it had been at a Thornlie or Gosnells car yard.

Horace got to work preparing the Phaeton for registration. It had never had a "body off" restoration and was a "bitzer", with a 1928 diff and engine. The body was sound and fairly original. The hood had to be refurbished. Because there is so much wood in 1930 Model A's, there was far too much movement to be safe, so the doors were strengthened. He worked on the steering and the brakes, and changed the front axle.

One day Horace drove it to Steve Read's for checking, but Steve was busy and suggested that he return in the afternoon. While returning home, he had a problem: a corroded cylinder head gave way and ended up with a hole the size of a 10 cent piece. He phoned Jean who grabbed a tow rope and came to tow the Model A home. Horace went to Steve's as planned in the afternoon, but without the Model A. Steve offered him a choice from his collection, and Horace returned home to replace the cylinder head, then took the Model A back to Steve's the next day. One day, driving to show the Phaeton to a dear friend, a neighbor near their old home, they went over some railway tracks and all the doors blew open. On returning home, Horace readjusted the door locks.

Horace took the engine to Southside Engineering Reconditioners in Myaree, on the recommendation of Alex Kirkwood. They rebored the cylinders, doing a good job and completing it quickly. During this time, he used the engine from the 1930 Tudor which is his next project. Other than having the engine rebored, Horace did it all himself. He made a lot of the bits he needed. He got good advice from Steve Read and other club members. The whole process was good experience – he knows what to do for the next one!

The Phaeton was registered on 18 December 2009. The Registration Number was 1DFZ 463. Horace attempted to arrange a registration plate from Morawa, but was unsuccessful. When they were holidaying in Shark Bay in 2011, he went into the Shire Office to see if he could get one there, and found there was no problem. So he requested 1930 SB, which was delivered to the metropolitan licensing centre in Kelmscott. He learned later that club member Brett Pollock was involved in the design of the Shark Bay logo during his time as Shire President there.

Horace and Jean enjoyed the Woolleen trip in 2012 but did not take a Model A. Instead they towed the first Teardrop Caravan Horace made.

They enjoyed the wonderful tour of a working station.

They particularly enjoyed the shakedown run to Busselton in September 2013, in preparation for the National Meet in September 2014. The weather was terrible, but it was the Phaeton's longest ever outing, to Busselton, Augusta and Molloy Island.



Horace has good memories of the weekend run to Cunderdin in June 2011, organized by Peter Sartori.

Horace and Jean Misko 2015

GOLDFIELDS TRIP

Alan Jeffree

REPORT on the GOLDFIELDS TRIP - organised by Peter Eardley through the Esperance VCC

All of our members who have an email address were sent the details of Peter’s Goldfields trip some weeks ago.

Brett Pollock with me as mechanic and Bob Piercy in his Phaeton joined the group in Coolgardie for the weeks outing. During the tour we visited Coolgardie, Kalgoorlie, Orabanda, Rolls Lagoon (overnight camp out), Siberia, Menzies, Leonora (overnight camp out), Gwalia, Melita, Kookyne, Niagra (overnight camp at the dam). To finish we had two nights at the Albion Motel in Kalgoorlie. On the final Sunday the twelve males in the groups spent the day prospecting using metal detectors with a professional from Kalgoorlie while the ladies rested in town. Unfortunately no gold was found! The pictures can tell the story!

Our first night at Karalee Rocks (just north of Southern Cross)



Orabanda Hotel



Coolgardie day two



13 3 2015



Original Gwalia garage



Three Model A's at Gwalia Ghost town shops



Our black tie evening and roast night at Niagra Dam

THE ELECTRICAL SYSTEMS

by Ray Mahony

MAGNETISM (continued)

The polarity of an electro-magnet is determined by the direction of the winding and the direction of the current flow. If you change the direction of the winding, the polarity will change and if you change the direction of the current flow, the polarity will change. If you change both at the same time, then the polarity will be the same as before.

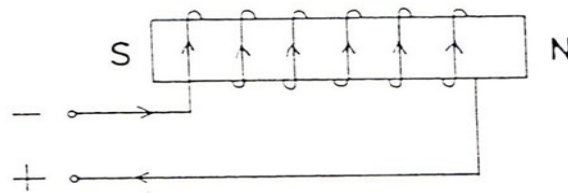

An established electromagnet

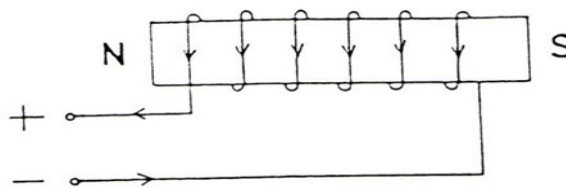

Polarity changed by altering direction of current flow

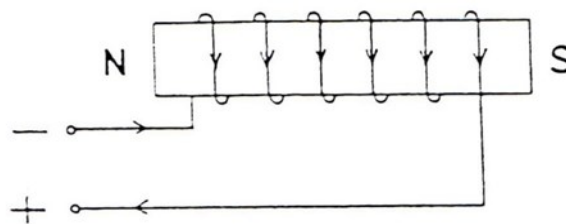

Polarity changed by reversing direction of windings

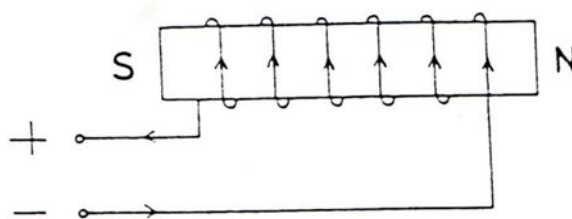

Polarity is unaltered if both current flow and coil windings are reversed

ELECTRICITY AND MAGNETISM

Ray Mahony—cont'd

Multiple magnets can be used to either increase or decrease the overall strength of the magnet. The strength of an electro-magnet fields is stated as the **ampere-turn value**; ie. the number of turns in the winding multiplied by the current flowing.

Coils wound to increase the magnetic effect.

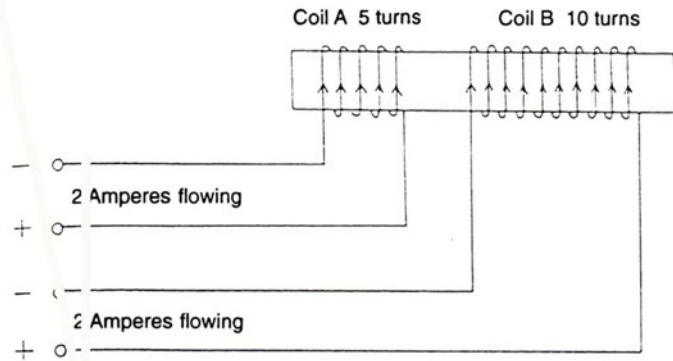

Coils wound to reduce the magnetic effect.

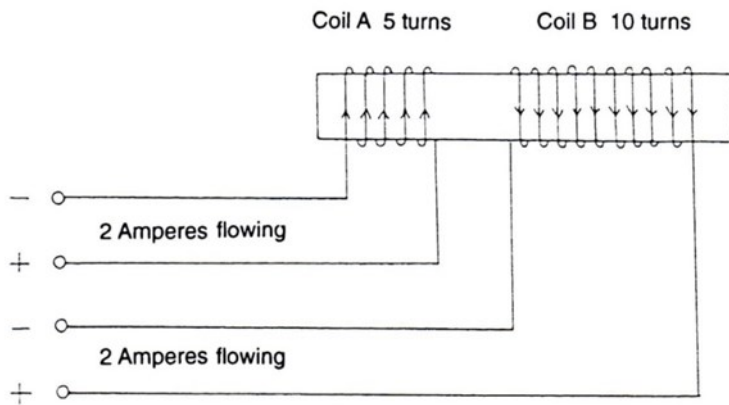

CLASSIFIEDS

For Sale: Model T Rod.

Contact: Andrew 0422 449 938



Cont'd

For Sale: Various Model A Items

- Shell fuel can (2 gal), red colour. Running board style. \$40.
- 19" tubes, new in wrapping (rubber stem) 5 tubes to sell. \$125
- 1930, 19" wheel. \$50

Contact: John Laurie. 0400 454 555.

For Sale: 1928 Model A Ford Roadster

Complete with hood bows, seat springs, two spare front mudguards.

Full set (5) of excellent 21" wheels and Hubcaps, new door locks, bonnet apron, and other hardware to go with it. Runs and drives. Comes complete with powdercoated windscreen frame, new windshield glass and stanchions. All the hard to find items are on the car.

\$16,000.00

Contact: Ron Andrews. 0411 889 825

**VEHICLE EXAMINATIONS****Ray Mahony (Registrar)**

Date: Sunday 10th May

Time: 8am and Midday

Location: VCC Club facility in Hale Rd, Forrestfield

Even though the Department of Transport no longer requires annual inspections for concession 404 vehicle registrations, our Club decided that such examinations are in the best interest of our members. In the past years examiners have found problems, mostly minor, that the owner was not aware of, which could have developed into major issues, sometimes effecting safety. The Club by-laws have always required annual inspection of both fully and concessionally registered vehicles but last year our Club decided to make inspections voluntary.

Annual examinations are a service to Club members to help them keep their Model A in a safe and reliable condition even though the Department of Transport now states that it is the responsibility of each owner to see their vehicle is maintained.

Inspections are held at the **VCC Club facility in Hale Rd, Forrestfield on Sunday 10th May**, between 8am and Midday. Morning tea and a sausage sizzle will be available.

See you and your Model A there



Please support these valued sponsors

RAY ABBOTT ENGINE RECONDITIONING
“RECONDITIONING THE PAST
SPECIALISING IN VETERAN, VINTAGE & CLASSIC ENGINES
FIFTY FOUR YEARS EXPERIENCE : IN BUSINESS FOR 41YEARS



CYLINDER HEAD SERVICING,REBORING, RESLEEING, CONROD RESIZING & BUSHING, LINE BORING & REMETALLING
 CRANK REGRINDS, PRESSURE TESTING, PISTON GRINDING &/OR EXPANDING, CAMSHAFT GRINDING .

COMPLETE ENGINE REBUILDS

18 Rio Street, Bayswater

PHONE 08 9272 4566 FAX 08 9271 5717

Rebuilding Oldies Better Than New

Recommended by MARCWA members

VETERAN, VINTAGE, CLASSIC LUBRICANTS & ELECTRICAL

Halogen Bulbs 6v & 12v Tungsten Bulbs 6v & 12v Indicator Stalks
 Flasher cans 6v & 12v Tail lights Indicator Lights (over 30 different types)
 Fuel Pumps 6v & 12v Wiper Motors 6v & 12v Wiper Blades

Cables (Cotton Covered, Metal Covered, PVC)
 High Tension Cable (Cotton Covered, Black PVC)

Spark Plugs 19” and 21” Model A Tyres Tubes Rust bands

and All Things Vintage

Bob Beames 6 Rio Street, Bayswater WA 6053
 Mob: 0419 276 411 Ph: 9272 6411 Fax: 9370 1506

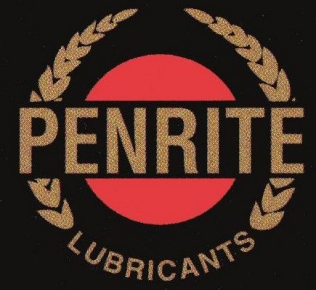

Obsession with oil



FORD MODEL T & A PARTS



Keith & Glenys Eastwood
 129 Balance Road
 Ballan 3342
 VICTORIA, AUSTRALIA

Ph (03) 5368 1088
 Fax (03) 5368 1007
 Mobile 0402194723

kg@henryspares.com.au

